

Solenoid valves for air VAA

TECHNICAL INFORMATION

- Suitable for a max. inlet pressure of 500 mbar (7 psig)
- Compact design saves space
- No extra valve required owing to integrated flow adjustment
- Check indication by blue LED
- Position switch with visual position indicator
- Bypass can be adjusted as desired
- Suitable for high-duty cycling



Contents

Contents	2	8 Technical data	20
1 Application	3	8.1 Ambient conditions	20
1.1 Application examples	4	8.2 Mechanical data	20
1.2 Configuring VAA	5	8.3 Electrical data	21
2 Certification	6	8.4 kv value	21
2.1 Certificate download	6	9 Dimensions	22
2.2 EU certified	6	9.1 VAA with Rp internal thread [mm]	22
2.3 ANSI/CSA approved	6	9.2 VAA with NPT internal thread [inch]	23
3 Function	7	9.3 VAA 2–3 with ISO flange [mm]	24
3.1 Solenoid valve for air VAA../N, quick opening	7	10 Converting units	25
3.2 Solenoid valve for air VAA../L, slow opening	8	11 Maintenance cycles	26
3.3 Solenoid valve for air VAA../R, slow opening and closing	8	For more information	27
3.4 Solenoid valve for air VAA..S/VAA..G, position switch (PS) with visual position indicator	9		
3.5 Connection diagram	10		
4 Flow rate	11		
4.1 Calculating the nominal size	11		
4.2 VAA flow rate diagram	12		
4.3 Bypass flow rate	14		
5 Selection	15		
5.1 ProFi	15		
5.2 Selection table	15		
6 Project planning information	17		
6.1 Installation	17		
6.2 Variable bypass	17		
7 Accessories	18		
7.1 Pressure switch for gas DG..C	18		
7.2 DG..C fastening set for VAx 1–3	19		
7.3 Variable bypass VAA /B	19		
7.4 Pressure test nipples	19		

1 Application

The valVario solenoid valve for air VAA is used for the staged control of industrial burners in cold air operating mode.

The modular design principle allows the individual components of the VAA series to be easily assembled, for example quick opening, slow opening, with position switch, with mounted pressure switch and with a variable bypass.

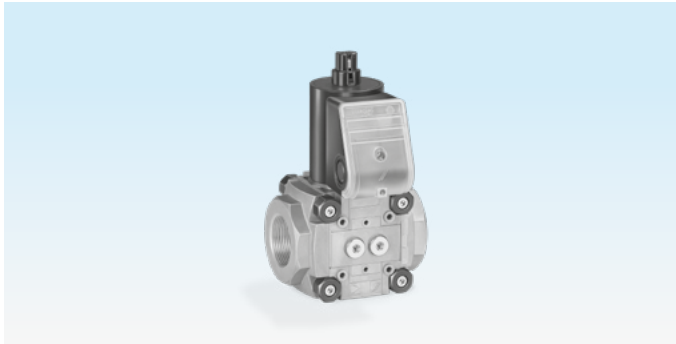

VAA, quick opening



VAA with damping



VAA with position switch



VAA with bypass

1.1 Application examples



Metallurgical industry: forging furnace



Ceramics industry: intermittent shuttle kiln

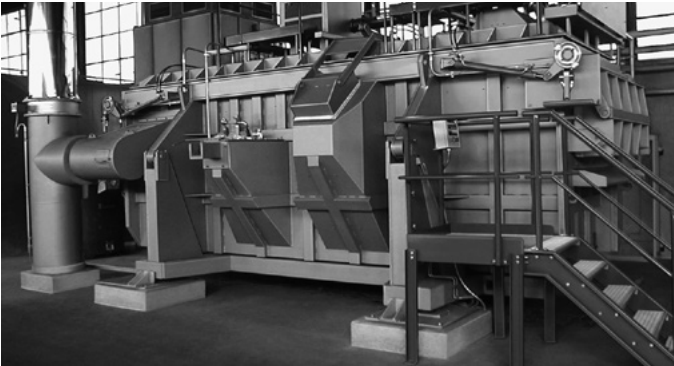

Aluminium industry: smelting furnace

1.2 Configuring VAA

Threaded flange for pipe connections (Rp or NPT) from DN 15 to 65, flanged connection (ISO) for size 2 for DN 40 pipe connections and for size 3 for DN 50 pipe connections.

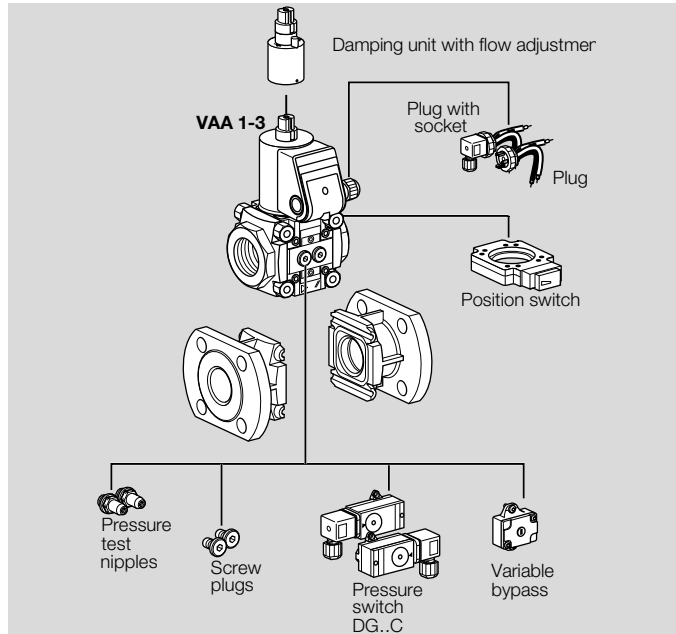

Modularly configurable with:

- Damping unit
- Position switch
- Plug (with or without socket)
- Pressure test nipples
- Screw plugs
- Pressure switch DG..C for inlet and/or outlet pressure
- Variable bypass (on both sides)

2 Certification

2.1 Certificate download

Certificates – see www.docuthek.com

2.2 EU certified



- 2014/35/EU (LVD), Low Voltage Directive
- 2014/30/EU (EMC), Electromagnetic Compatibility Directive
- 2011/65/EU, RoHS II
- 2015/863/EU, RoHS III
- based on EN 161

2.3 ANSI/CSA approved



American National Standards Institute/Canadian Standards Association

ANSI/UL429 Electrically operated valves – CSA C22.2 No. 139–19 Electrically operated valves.

3 Function

The solenoid valve for air VAA is closed when de-energized.

Opening: connect the system to the electrical power supply (alternating voltage will be rectified). The blue LED lights up. The coil's magnetic field pulls the armature with the attached valve plates upwards. The solenoid valve for air VAA opens. The double valve seat means that the forces from the inlet pressure are divided almost equally between the two valve seats.

Closing: disconnect the VAA from the electrical power supply. The blue LED goes out. The armature is pressed into its initial position by the closing spring. The solenoid valve for air closes within 1 s.

The flow rate can be varied by a flow adjusting screw on the actuator within a range from 20 to 100%. The setting can be monitored on an indicator.

3.1 Solenoid valve for air VAA../N, quick opening

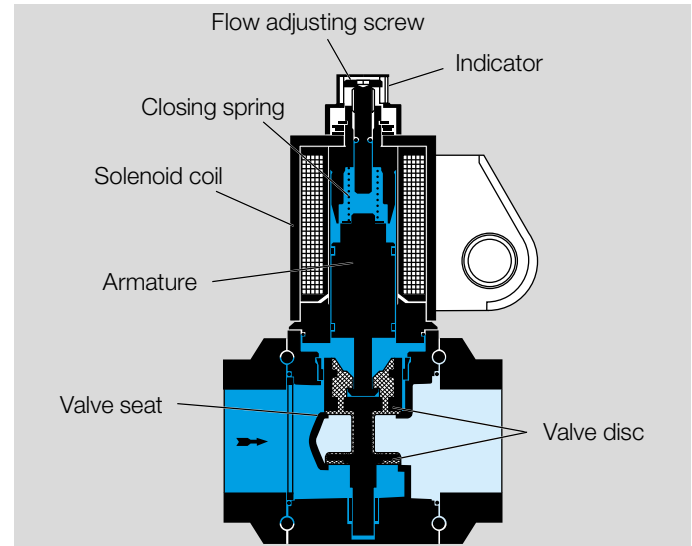

VAA 1-3../N

The solenoid valve for air VAA../N opens within 0.5 s.

3.2 Solenoid valve for air VAA../L, slow opening

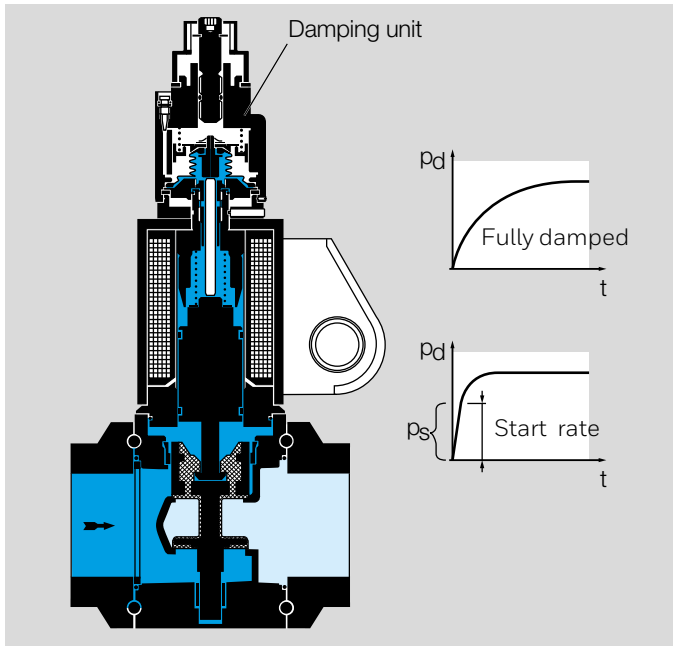

VAA 1-3../L

The solenoid valve for air VAA../L opens within 10 s.

Start rate adjustment: the solenoid valve for air opens with a quick initial lift and then continues slowly until it is fully open. The start rate can be set.

By turning the damping unit, the start rate can be set between 0 and 70%:

Turning it clockwise will decrease the start rate and turning it anticlockwise will increase the start rate.

3.3 Solenoid valve for air VAA../R, slow opening and closing

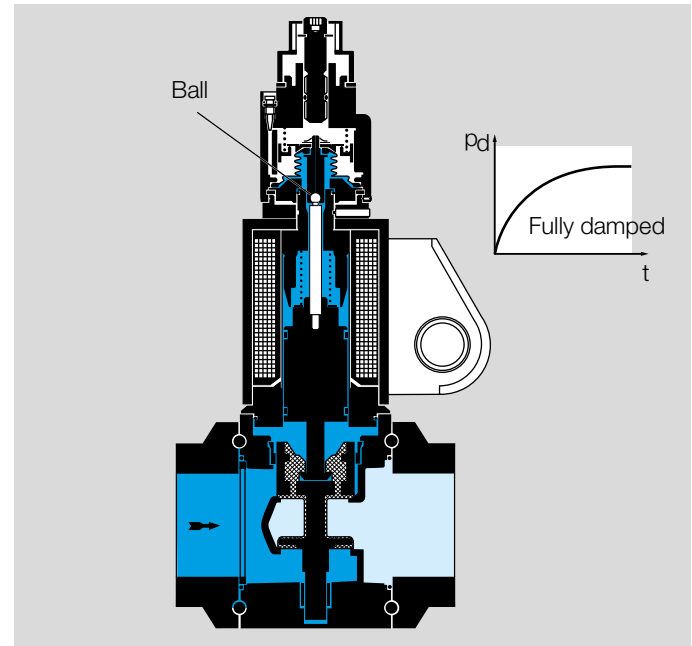

VAA 1-3../R

The solenoid valve for air VAA../R opens and closes within 4 s.

The stem of the iron core is connected to the damping spindle via a ball. This connection ensures that the closing movement is damped.

3.4 Solenoid valve for air VAA..S/VAA..G, position switch (PS) with visual position indicator

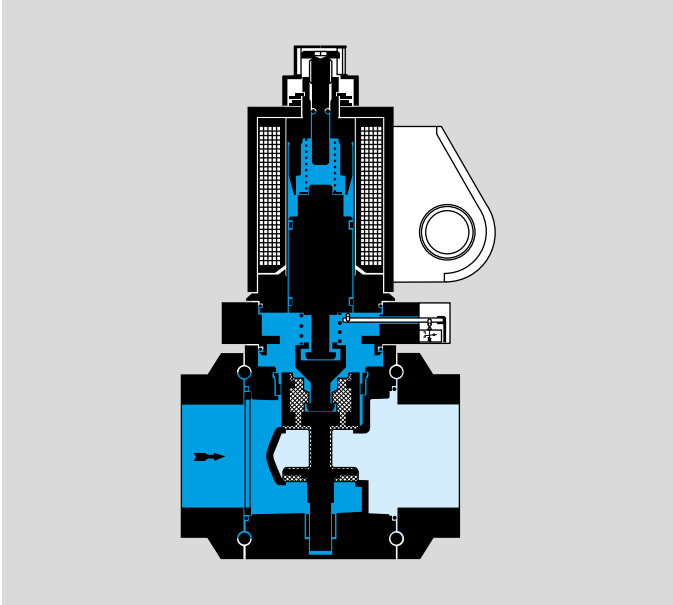

VAA 1–3..S, VAA 1–3..G

Opening: when the air solenoid valve is opened, the position switch is operated first. The visual position indicator is activated. The “open” signal is marked in red. Only then does the double valve seat open to release the volume of air (overtravel principle).

Closing: the air solenoid valve VAA is disconnected from the electrical power supply and the closing spring presses the double valve plate on to the valve seat. Then the position

switch is actuated. The visual position indicator is white for “closed”.

The actuator cannot be rotated on air solenoid valves with position switch.

3.5 Connection diagram

Wiring to EN 60204-1.

VAA with M20 cable gland

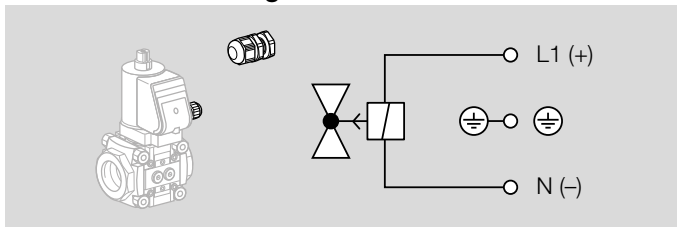

VAA with plug

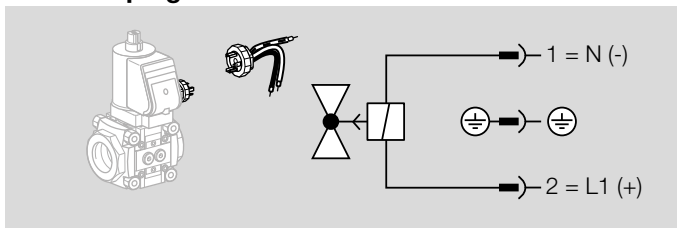

VAA..S, VAA..G with position switch and visual position indicator

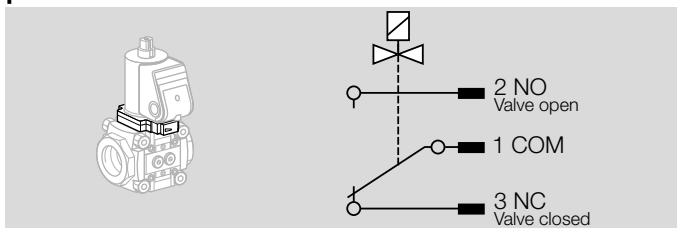

4 Flow rate

4.1 Calculating the nominal size

A web app for calculating the nominal size is available at www.adlatus.org.

4.2 VAA flow rate diagram

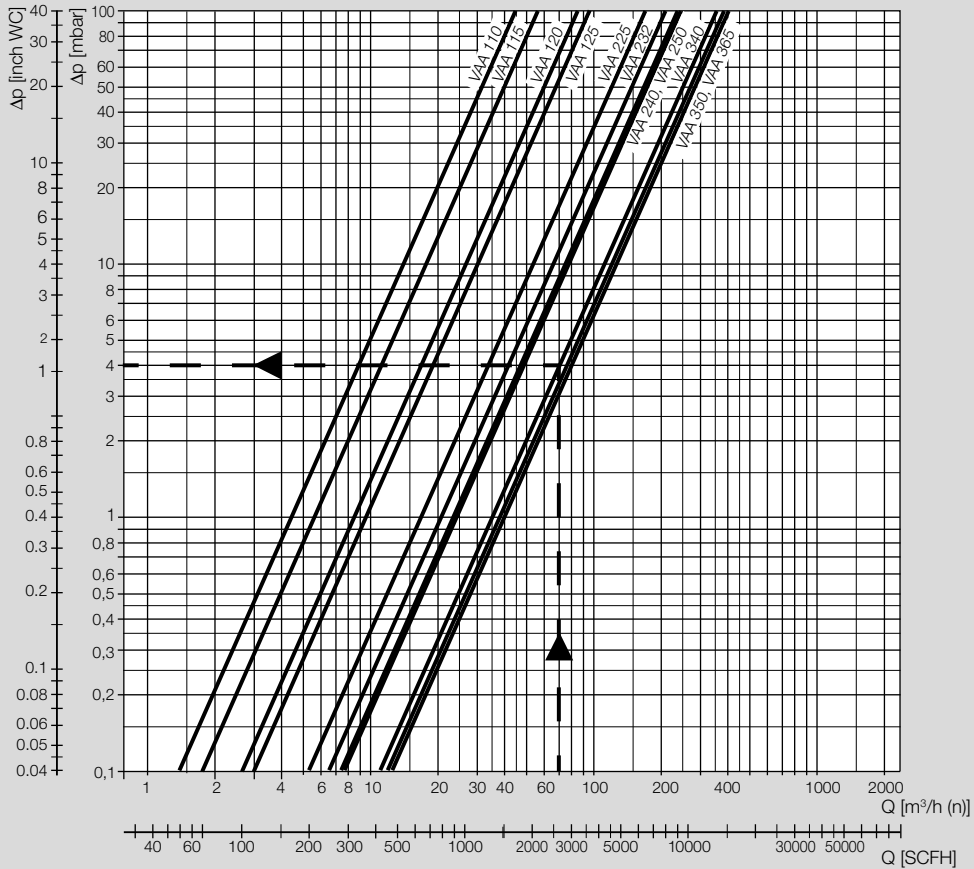

Air ($\rho = 1.29 \text{ kg/m}^3$)

The characteristic flow rate curves have been measured with the specified flanges .

* $Q_{\text{min.}}$ = rough specification for fully restricted flow adjustment and $\Delta p_{\text{max.}}$.

When determining the pressure loss, operating cubic metres must be entered. Then the pressure loss Δp read must

4 Flow rate

be multiplied by the absolute pressure in bar (positive pressure + 1) to account for the change in the medium's density.

Example

inlet pressure p_u (positive pressure) = 0.3 bar,

gas type: air,

operating flow rate $Q = 70 \text{ m}^3/\text{h}$ (b),

Δp from diagram = 4 mbar,

$\Delta p = 4 \text{ mbar} \times (1 + 0.3) = 5.3 \text{ mbar}$ on the

solenoid valve for air VAA 340

4.3 Bypass flow rate

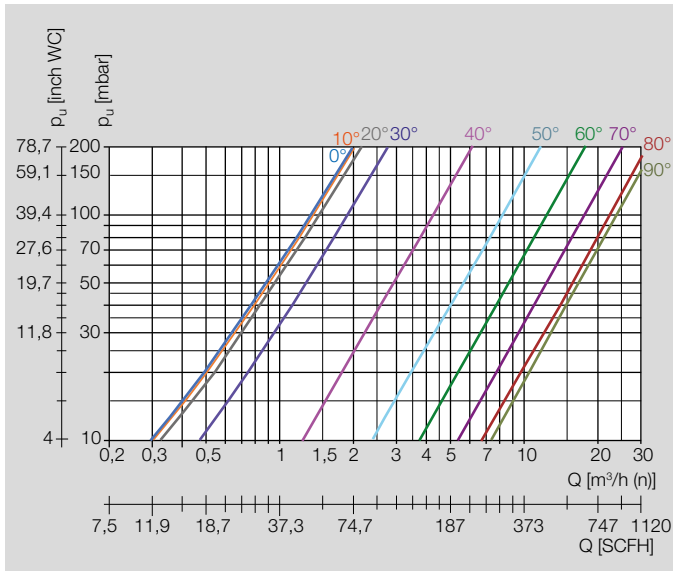

The characteristic flow rate curves have been measured with the valve closed.

The setting for the opening angle in the bypass depends on the supply pressure and air requirement.

5 Selection

5.1 ProFi

A web app selecting the correct product is available at www.adlatus.org.

5.2 Selection table

Description	Code	VAA 1	VAA 2	VAA 3	Condition
Air solenoid valve	VAA	•	•	•	
Sizes	1–3	1	2	3	
DN					
No flange	–	•	•	•	
Inlet and outlet flange nominal size	15–65	15, 25	15, 25, 32, 40, 50	40, 50, 65	
Pipe connection					
Rp internal thread	R	•	•	•	
Flange to ISO 7005	F		•	•	Flange version for size 2 and higher
NPT internal thread	N	•	•	•	
Opening properties					
Quick opening, quick closing	/N	•	•	•	
Slow opening, quick closing	/L	•	•	•	
Slow opening, slow closing	/R	•	•	•	
Mains voltage					
230 V AC, 50/60 Hz	W	•	•	•	
120 V AC, 50/60 Hz	Q	•	•	•	
24 V DC	K	•	•	•	
100 V AC, 50/60 Hz	P	•	•	•	
200 V AC, 50/60 Hz	Y	•	•	•	
Feedback					
Position switch and visual position indicator	S	•	•	•	
With position switch for 24 V and visual position indicator	G	•	•	•	

5 Selection

Description	Code	VAA 1	VAA 2	VAA 3	Condition
Viewing side					
Position switch right	R	•	•	•	Viewed from the right: looking into the valve body in the direction of flow.
Position switch left	L	•	•	•	Viewed from the left: looking into the valve body in the direction of flow.
Electrical connection		M20, plug, plug with socket	M20, plug, plug with socket	M20, plug, plug with socket	Viewing side for the electr. connection: looking at the connection box, see order example.
Accessories, right		Screw plug, test nipple, DG 17-300, bypass	Screw plug, test nipple, DG 17-300, bypass	Screw plug, test nipple, DG 17-300, bypass	Viewed from the right: looking into the valve body in the direction of flow, see order example. DG: specify the test point for inlet pressure p_u or outlet pressure p_d .
Accessories, left		Screw plug, test nipple, DG 17-300, bypass	Screw plug, test nipple, DG 17-300, bypass	Screw plug, test nipple, DG 17-300, bypass	Viewed from the left: looking into the valve body in the direction of flow, see order example. DG: specify the test point for inlet pressure p_u or outlet pressure p_d .

Order example

VAA 225R/NW

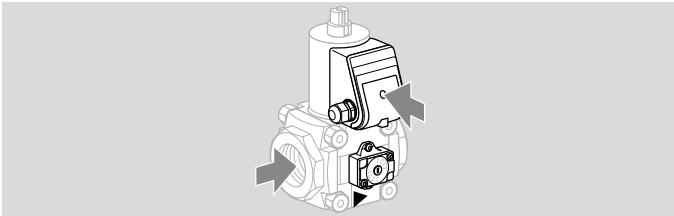

M20, fitted on the left (looking at the connection box)

Bypass, fitted on the right (looking into the valve body in the direction of flow)

Screw plug, fitted on the left (looking into the valve body in the direction of flow)

6 Project planning information

6.1 Installation

Do not store or install the unit in the open air.

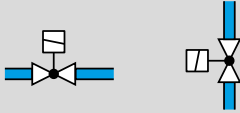

Installation position: black solenoid actuator in the vertical upright position or tilted up to the horizontal, not upside down.

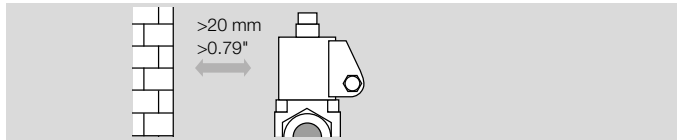

The device must not be in contact with masonry. Minimum clearance 20 mm (0.79 inches).

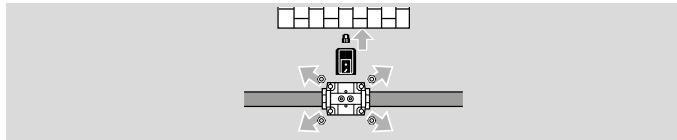

Ensure that there is sufficient space for installation and adjustment.

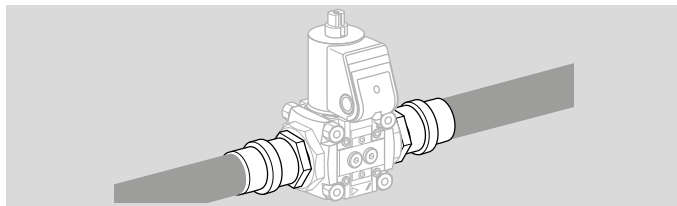

The seals in some gas compression fittings are approved for temperatures of up to 70°C (158°F). This temperature limit will not be exceeded if the flow through the pipe is at least 1 m³/h (35.31 SCFH) of gas and the maximum ambient temperature is 50°C (122°F).

6.2 Variable bypass

The system can be operated at burner low-fire rate or purge air using a variable bypass.

The bypass can only be configured for the solenoid valve for air VAA.

The flow rate is adjusted individually using the scale on the bypass. See page 14 (4.3 Bypass flow rate). The bypass is set to the closed position (0°) at the factory.

The bypass can be attached at the right- and/or left-hand side of the flow body.

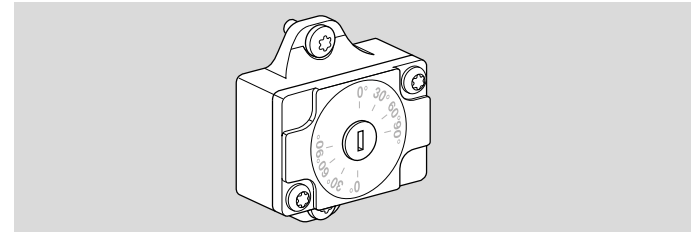

For retrofitting on the VAA, the bypass can be supplied as an additional item, see Accessories, page 19 (7.3 Variable bypass VAA /B).

7 Accessories

7.1 Pressure switch for gas DG..C

Monitoring the inlet pressure p_u : the electrical plug of the pressure switch for gas points towards the inlet flange.
Monitoring the outlet pressure p_d : the electrical plug of the pressure switch for gas points towards the outlet flange.

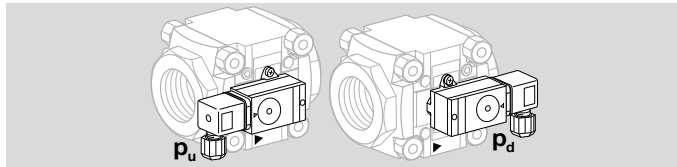

Scope of delivery:

- 1 x pressure switch for gas,
- 2 x retaining screws,
- 2 x sealing rings.

Also available with gold-plated contacts for voltages of 5 to 250 V.

DG..VC

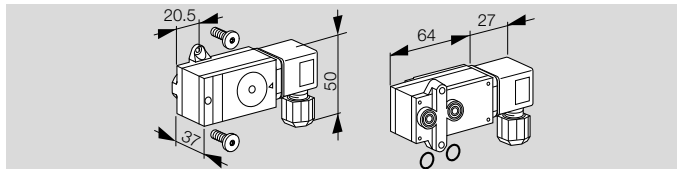

Type	Adjusting range [mbar]	Order No.
DG 17VC	2 to 17	75455241
DG 40VC	5 to 40	75455243
DG 45VC	10 to 45	75455244
DG 110VC	30 to 110	75455245
DG 300VC	100 to 300	75455246

Type	Adjusting range [mbar]	Order No.
With gold-plated contacts for voltages of 5 to 250 V		
DG 17VC..G	2 to 17	75455247
DG 40VC..G	5 to 40	75455249
DG 45VC..G	10 to 45	75455250
DG 110VC..G	30 to 110	75455251
DG 300VC..G	100 to 300	75455252

DG..VCT

With AWG 18 connection conductors

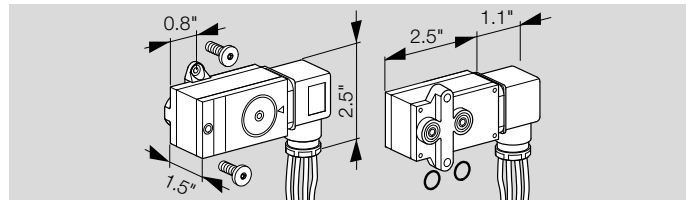

Type	Adjusting range [\"WC]	Order No.
DG 17VCT	0,8 to 6,8	75454583
DG 40VCT	2 to 16	74214174
DG 110VCT	12 to 44	75454585
DG 300VCT	40 to 120	75454586
With gold-plated contacts for voltages of 5 to 250 V		
DG 17VCT..G	0,8 to 6,8	75454587
DG 40VCT..G	2 to 16	75454588
DG 110VCT..G	12 to 44	75454589
DG 300VCT..G	40 to 120	75454590

7.2 DG..C fastening set for VAx 1–3

Order No.: 74922376,
scope of delivery:
2 x retaining screws,
2 x sealing rings.

7.3 Variable bypass VAA /B

For retrofitting on the VAA, the bypass can be supplied as an additional item.

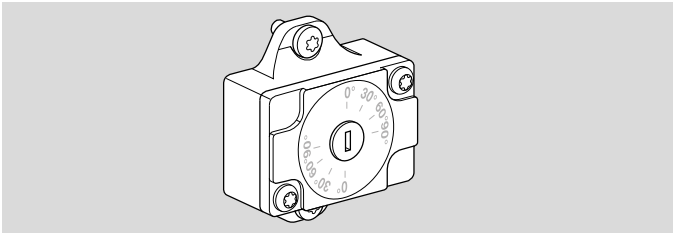

The bypass can be attached at the right- and/or left-hand side of the flow body.

Order No.: 74926325

7.4 Pressure test nipples

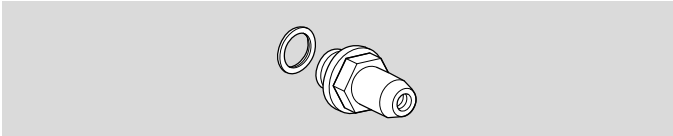

Scope of delivery

1 x test nipple with 1 x profiled sealing ring,
Rp 1/4: Order No. 74923390.

1 x test nipple (steel) with 1 x profiled sealing ring (Viton),
1/4 NPT: Order No. 74921869.

8 Technical data

8.1 Ambient conditions

Icing, condensation and dew in and on the unit are not permitted.

Avoid direct sunlight or radiation from red-hot surfaces on the unit. Note the maximum medium and ambient temperatures!

Avoid corrosive influences, e.g. salty ambient air or SO₂.

The unit may only be stored/installed in enclosed rooms/buildings.

The unit is suitable for a maximum installation height of 2000 m AMSL.

Ambient temperature: -20 to +60°C (-4 to +140°F), no condensation permitted.

Long-term use in the upper ambient temperature range accelerates the ageing of the elastomer materials and reduces the service life (please contact manufacturer).

Storage temperature = transport temperature: -20 to +40°C (-4 to +104°F).

Enclosure: IP 65.

This unit is not suitable for cleaning with a high-pressure cleaner and/or cleaning products.

8.2 Mechanical data

Gas types: clean air. The air must be clean and dry in all temperature conditions and must not contain condensate.

Medium temperature = ambient temperature.

CE approved, max. inlet pressure p_U : 500 mbar (7.25 psig).

Flow adjustment limits the maximum flow rate to between approx. 20 and 100%.

Adjustment of the start rate: 0 to approx. 70%.

Opening times:

VAA../N quick opening: < 1 s;

VAA../L slow opening: up to max. 10 s,

VAA../R slow opening: 4 s.

Closing time:

VAA../N, VAA../L quick closing: < 1 s,

VAA../R slow closing: 4 s.

Switching frequency:

VAA../N: any, max. 30 x per minute.

VAA../L: max. 2 x per minute. There should be a period of 20 seconds between switching off and on again so that the damping is fully effective.

VAA../R: max. 6 x per minute.

Valve housing: aluminium,
valve seal: EPDM.

Connection flanges:

up to size 3: Rp internal thread to ISO 7-1, NPT to ANSI/ASME;

size 2 and higher: with PN 16 ISO flange (pursuant to ISO 7005) .

Cable gland: M20 x 1.5.

Electrical connection: cable with max. 2.5 mm² (AWG 12) or plug with socket to EN 175301-803.

Duty cycle: 100%.

Power factor of the solenoid coil: $\cos \varphi = 0.9$.

8.3 Electrical data

Mains voltage:

230 V AC, +10/-15%, 50/60 Hz;
 200 V AC, +10/-15%, 50/60 Hz;
 120 V AC, +10/-15%, 50/60 Hz;
 100 V AC, +10/-15%, 50/60 Hz;
 24 V DC, ±20%.

Power consumption:

Type	Voltage	Power
VAA 1	24 V DC	25 W
VAA 1	100 V AC	25 W (26 VA)
VAA 1	120 V AC	25 W (26 VA)
VAA 1	200 V AC	25 W (26 VA)
VAA 1	230 V AC	25 W (26 VA)
VAA 2, VAA 3	24 V DC	36 W
VAA 2, VAA 3	100 V AC	36 W (40 VA)
VAA 2, VAA 3	120 V AC	40 W (44 VA)
VAA 2, VAA 3	200 V AC	40 W (44 VA)
VAA 2, VAA 3	230 V AC	40 W (44 VA)

Contact rating of position switch:

Type	Voltage	Current (resistive load)	
		min.	max.
VAA..S	12–250 V AC, 50/60 Hz	100 mA	3 A
VAA..G	12–30 V DC	2 mA	0.1 A

Switching frequency of position switch: max. 5 x per minute.

Switching current	Switching cycles*	
	cos φ = 1	cos φ = 0.6
0.1	500,000	500,000
0.5	300,000	250,000
1	200,000	100,000
3	100,000	–

* Limited to max. 200,000 cycles for heating systems.

8.4 kv value

k_V = Valve coefficient (k_V min. = rough specification for fully restricted flow adjustment)

Type	k_V max. m ³ /h	k_V min. m ³ /h
VAA 115	6.4	2
VAA 120	9.6	2
VAA 125	10.9	2
VAA 225	19.2	5.3
VAA 232	24.1	5.3
VAA 240	26.7	5.3
VAA 250	27.2	5.3
VAA 340	38.6	8.5
VAA 350	41.8	8.5
VAA 365	43.5	8.5

9 Dimensions

9.1 VAA with Rp internal thread [mm]

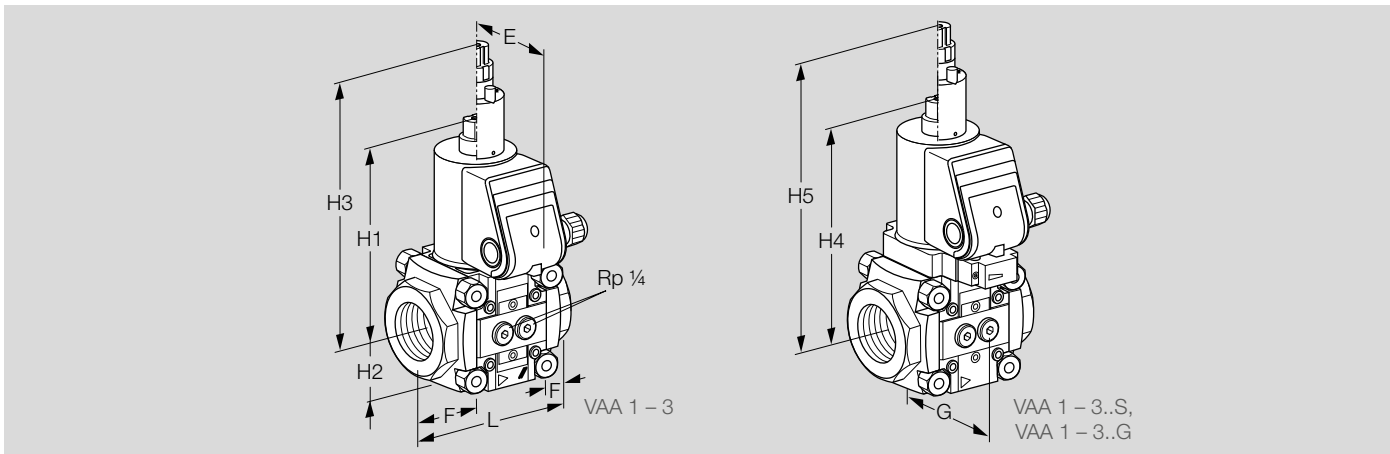

Type	Connection		Dimensions [mm]									Weight [kg]
	Rp	DN	L	E	F	G	H1	H2	H3	H4	H5	
VAA 115	1/2	15	75	75	15	67.3	143	32	208	161	226	1.4
VAA 120	3/4	20	91	75	23	67.3	143	32	208	161	226	1.5
VAA 125	1	25	91	75	23	67.3	143	32	208	161	226	1.4
VAA 225	1	25	127	85	29	98.2	170	47	235	191	256	3.8
VAA 232	1 1/4	32	127	85	29	98.2	170	47	235	191	256	3.8
VAA 240	1 1/2	40	127	85	29	98.2	170	47	235	191	256	3.8
VAA 250	2	50	127	85	29	98.2	170	47	235	191	256	3.6
VAA 340	1 1/2	40	155	85	36	113.3	180	59	245	201	266	5.2
VAA 350	2	50	155	85	36	113.3	180	59	245	201	266	5.0
VAA 365	2 1/2	65	155	85	36	113.3	180	59	245	201	266	4.8

9.2 VAA with NPT internal thread [inch]

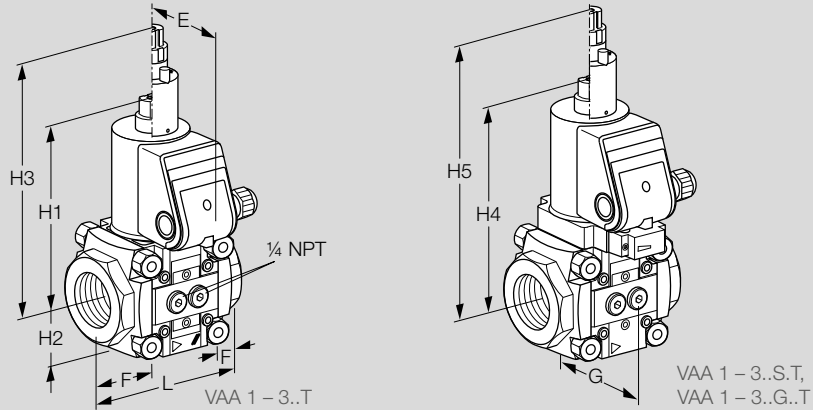

Type	Connection		Dimensions [inch]									Weight [lbs]
	NPT	DN	L	E	F	G	H1	H2	H3	H4	H5	
VAA 115	1/2	15	2.95	2.95	0.59	2.65	5.63	1.26	8.19	6.34	8.9	3.08
VAA 120	3/4	20	3.58	2.95	0.91	2.65	5.63	1.26	8.19	6.34	8.9	3.30
VAA 125	1	25	3.58	2.95	0.91	2.65	5.63	1.26	8.19	6.34	8.9	3.08
VAA 225	1	25	5.00	3.32	1.14	3.87	6.69	1.85	9.25	7.52	10.1	8.36
VAA 232	1 1/4	32	5.00	3.32	1.14	3.87	6.69	1.85	9.25	7.52	10.1	8.36
VAA 240	1 1/2	40	5.00	3.32	1.14	3.87	6.69	1.85	9.25	7.52	10.1	8.36
VAA 250	2	50	5.00	3.32	1.14	3.87	6.69	1.85	9.25	7.52	10.1	7.92
VAA 340	1 1/2	40	6.10	3.32	1.42	4.46	7.09	2.3	9.65	7.91	10.5	11.40
VAA 350	2	50	6.10	3.32	1.42	4.46	7.09	2.3	9.65	7.91	10.5	11.00
VAA 365	2 1/2	65	6.10	3.32	1.42	4.46	7.09	2.3	9.65	7.91	10.5	10.56

9.3 VAA 2-3 with ISO flange [mm]

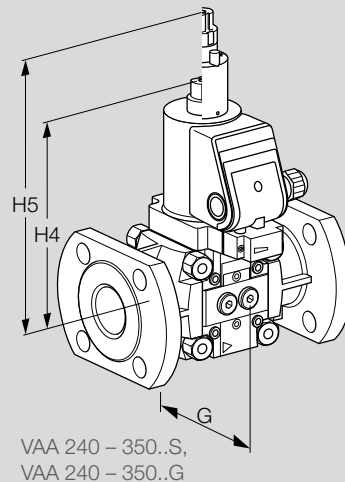
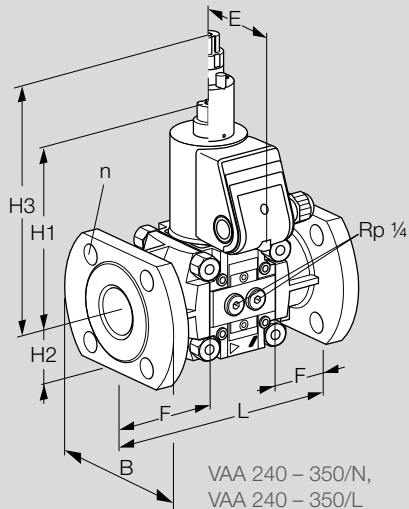

Type	Connection DN	Dimensions [mm]										n	Weight [kg]
		L	E	F	G	B	H1	H2	H3	H4	H5		
VAA 240	40	200	85	66	98.2	150	175	56	240	196	258	4	5
VAA 350	50	230	85	74	113.3	165	180	65	245	200	265	4	6.5

10 Converting units

See www.adlatus.org

11 Maintenance cycles

VAA requires little servicing.

We recommend a function check once a year.

For more information

The Honeywell Thermal Solutions family of products includes Honeywell Combustion Safety, Eclipse, Exothermics, Hauck, Kromschroder and Maxon. To learn more about our products, visit ThermalSolutions.honeywell.com or contact your Honeywell Sales Engineer.

Elster GmbH
Strotheweg 1, D-49504 Lotte
T +49 541 1214-0
hts.lotte@honeywell.com
www.kromschroeder.com

© 2023 Elster GmbH

We reserve the right to make technical modifications in the interests of progress.

