

Thermal equipment trip TAS

Manual valve with thermal equipment trip AKT..TAS

TECHNICAL INFORMATION

- Isolate the gas pipeline in the event of a fire
- High thermal capacity
- AKT..TAS: two controls in one housing
- EC-type tested and registered

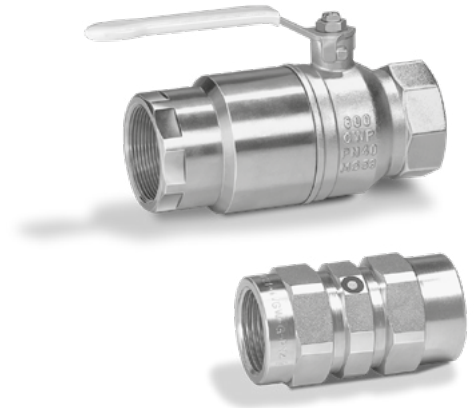

Contents

Contents	2
1 Application	3
1.1 Application examples	5
2 Certification	6
3 Function	7
4 Flow rate	8
4.1 Calculating the nominal size	8
5 Selection	9
5.1 ProFi	9
5.2 TAS	9
5.2.1 Type code	9
5.3 AKT..TAS	9
5.3.1 Type code	10
6 Project planning information	11
6.1 Installation	11
7 Accessories	12
7.1 Flange seals for AKT..TAS	12
8 Technical data	13
8.1 Dimensions	14
8.1.1 TAS	14
8.1.2 AKT..TAS	16
9 Maintenance cycles	17
Fore more information	18

1 Application

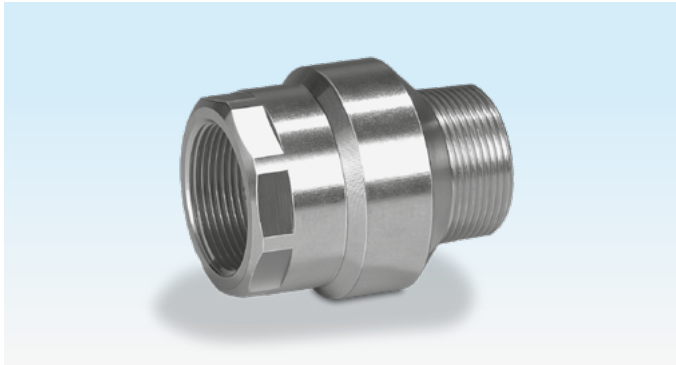

TAS: the thermal equipment trip shuts off pipelines safely up to 650°C.



AKT..TAS: the space-saving combination of a manual valve and a thermally tripping shut-off valve offers two functions in a single housing.

Thermal equipment trips can be used in industrial and commercial installations, upstream of gas inlet systems, at gas cooker points, instantaneous water heaters and gas boilers.

In the event of fire, they isolate the gas pipeline and provide long-term protection against the uncontrolled escape of gas and explosion. Valves AKT..TAS and TAS can be used pursuant to the German Firing System Directive and TRGI (DVGW Code of Practice G 600).

TAS

Automatically closing safety device

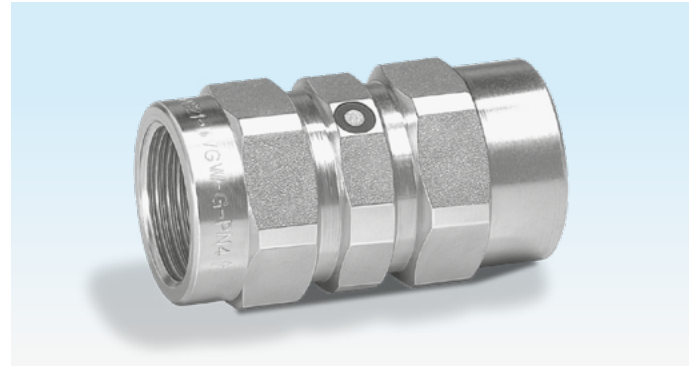

Thermal equipment trip TAS 15–25..M for biogas

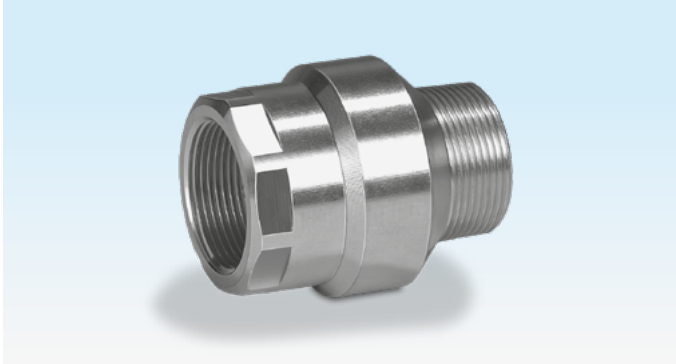

Thermal equipment trip TAS 32-50IA, internal and external threads



Manual valve with thermal equipment trip AKT..TAS, internal thread

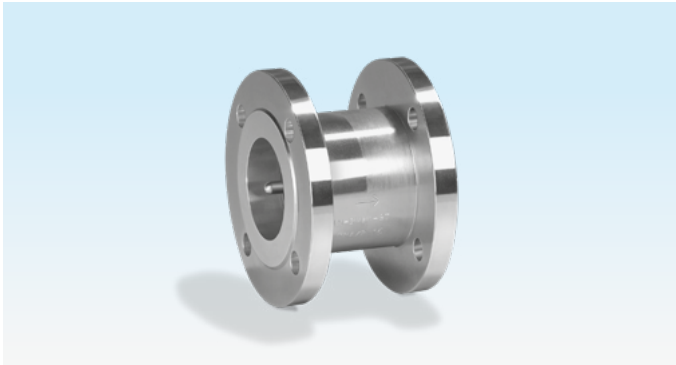

Thermal equipment trip TAS 32-200FF, flanged connection

AKT..TAS

Manual valve for manual shut-off, for gas, with automatically closing safety device



Manual valve with thermal equipment trip AKT 25-150F50TAS, flanged connection

1.1 Application examples

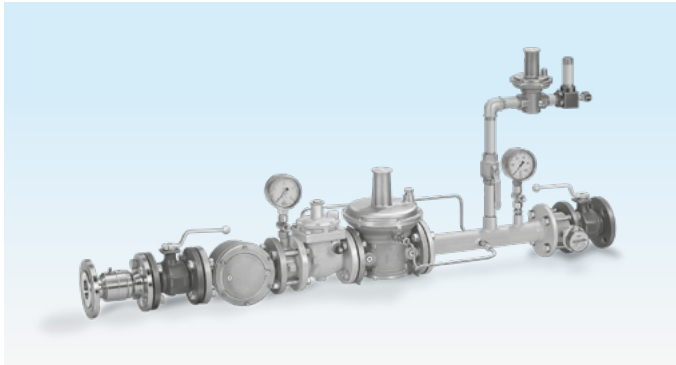

Gas pressure control (and measurement) system with TAS

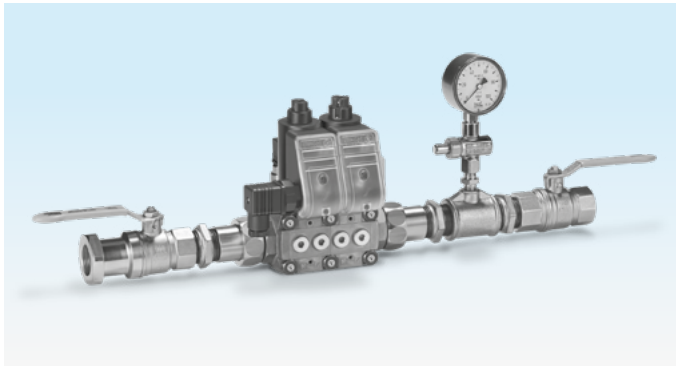

Kitchen safety equipment with AKT..R10TAS/AKT..R40TAS

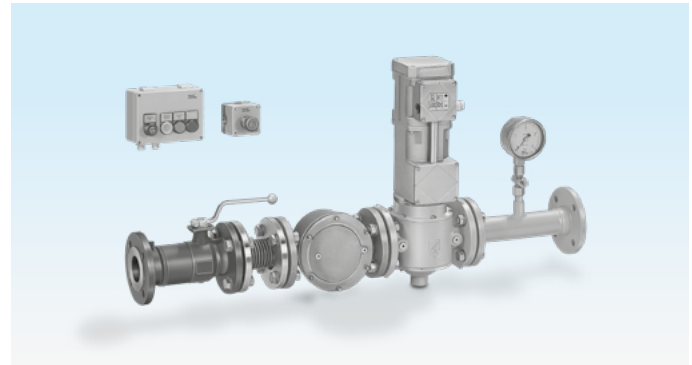

Main gas shut-off device with AKT..F50TAS

When a thermal equipment trip TAS or a manual valve with thermal equipment trip AKT..TAS (pursuant to TRGI) is installed, the gas safety system features enhanced fire protection.

If the ambient temperature increases to more than 95°C in the gas pressure control (and measurement) system with TAS, the thermal equipment trip TAS trips and shuts off the gas supply safely.

In the applications Kitchen safety equipment with AKT..R10TAS/AKT..R50TAS and Main gas shut-off device with AKT..F50TAS, the gas supply can be shut off manually at the inlet, in addition to the thermally tripping shut-off.

Reference standards

TRGI, paragraph 5.1, "... controls ... and measuring devices must be tight and designed ... in such a way that they ... do not lead to a risk of explosion in the event of exposure to an external fire."

2 Certification

Certificates – see www.docuthek.com

EU certified



- Gas Appliances Directive (2009/142/EC)

AKT..R10TAS and AKT..R40TAS

- Manually operated ball valves and closed bottom taper plug valves for gas installations in buildings (DIN EN 331)
- Thermally activated shutting-off devices for gas – Requirements and testing (DIN 3586)

AKT..R10TAS

- DVGW test mark NG-4341BR0234
- Gas Appliances Directive CE-0085BR0233

AKT..R50TAS

- DVGW test mark NG-4341BU0538
- Gas Appliances Directive CE-0085BU0539

AKT..F50TAS

- DVGW test mark NG-4341AT2766
- Gas Appliances Directive CE-0085AU2378

3 Function

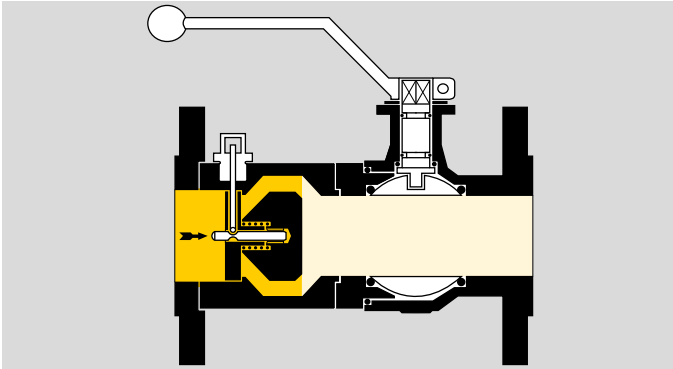

If the ambient temperature increases to more than 95°C in the event of a fire, a seal melts in the thermal equipment trip TAS and releases a spring that is held by a retaining pin. The spring presses the closing taper against the sealing seat ensuring that no more gas can pass through.

The valve can withstand temperatures of up to 650°C, which means that it remains tight for at least one hour.

4 Flow rate

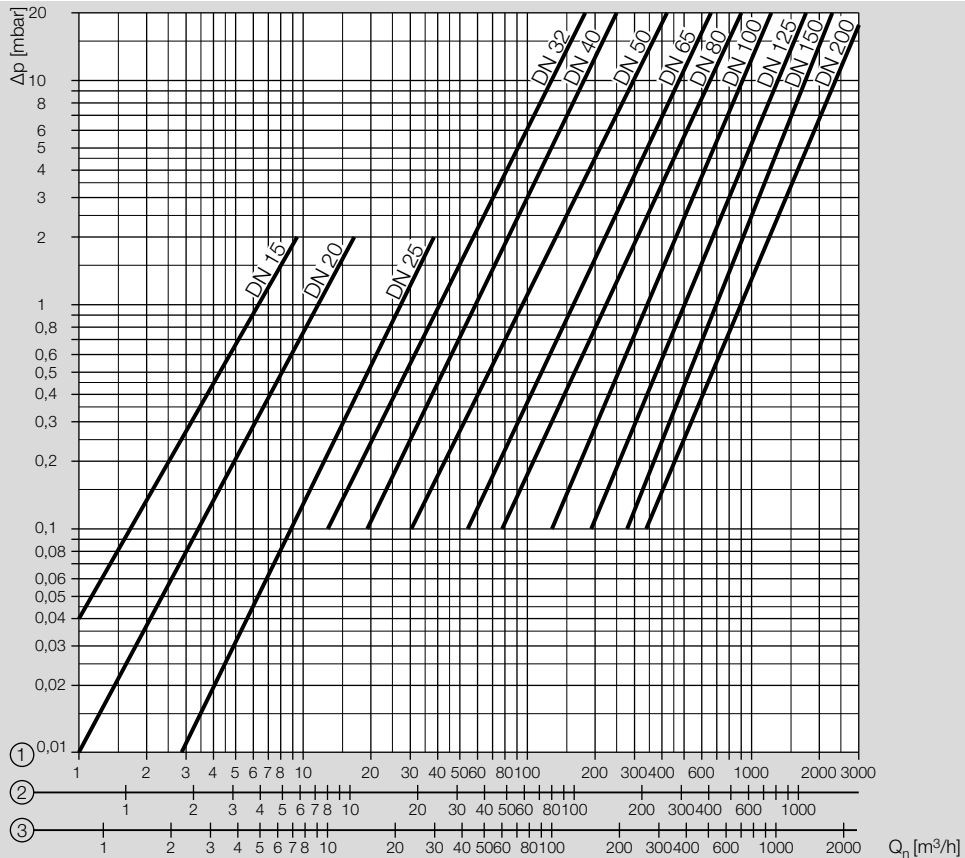

- 1 = natural gas ($\rho = 0.80 \text{ kg/m}^3$)
- 2 = propane ($\rho = 2.01 \text{ kg/m}^3$)
- 3 = air ($\rho = 1.29 \text{ kg/m}^3$)

4.1 Calculating the nominal size

A web app selecting the correct product is available at www.adlatus.org.

5 Selection

5.1 ProFi

A web app selecting the correct product is available at www.adlatus.org.

5.2 TAS

Option	TAS..I	TAS..F*	TAS..I..M	TAS..F..M*
DN	32, 40, 50	32, 40, 50, 65, 80, 100, 125, 150, 200	15, 20, 25, 32, 40, 50	25, 32, 40, 50, 65, 80, 100, 125, 150, 200
Inlet pipe connection	I	F	I	F
Outlet pipe connection	I, A	F	A	F
Inlet pressure	50	50	50	50
Suitable for biogas	–	–	M	M

Order example

TAS 32IA50

* If the TAS installation set (available on request) is being used, the thermal equipment trips TAS..F meet the high thermal capacity requirements for inlet pressures of up to a max. of 16 bar.

5.2.1 Type code

TAS	Thermal equipment trip
15–200	Nominal size
I	Rp internal thread inlet connection
F	DIN flange inlet connection
I	Rp internal thread outlet connection
A	R external thread outlet connection
F	DIN flange outlet connection
50	p_u max. 5 bar
M	For biogas

5.3 AKT..TAS

Option	AKT..R10	AKT..R50	AKT..F50
DN	15, 20, 25	32, 40, 50	25, 32, 40, 50, 65, 80, 100, 125, 150
Pipe connection	R	R	F
Inlet pressure	10	50*	50*
Thermal equipment trip	TAS	TAS	TAS

Order example

AKT 50R50TAS

* If the TAS installation set (available on request) is being used, the thermal equipment trips TAS..F meet the high thermal capacity requirements for inlet pressures of up to a max. of 16 bar.

5.3.1 Type code

AKT	Manual valve
15–150	Nominal size
R	Rp internal thread
F	Flange to ISO 7005
10	p_u max. 1 bar in the case of high thermal stress, otherwise max. 5 bar
50	p_u max. 5 bar*
TAS	Thermal equipment trip

6 Project planning information

6.1 Installation

Installation position as required.

Wall clearance minimum 20 mm, note manual valve rotational radius.

AKT..TAS or TAS are to be installed immediately upstream of equipment that must not be exposed to thermal stresses or equipment that is not resistant to high temperatures.

Paint coatings, insulation, protective covers, etc. are not permitted.

Use high temperature resistant flange seals on the inlet side.

7 Accessories

7.1 Flange seals for AKT..TAS

Use high temperature resistant flange seals on the inlet side, e.g. type WL-HT:

rubber seal made of NBR 50219.0, support ring made of ST 37, galvanized and chromized, coated with graphite on both sides and with red high temperature resistance label (HTB), seal material DVGW tested and registered.

8 Technical data

Gas types:

natural gas, town gas and LPG (gaseous). Fuel gases in accordance with DVGW Code of Practice G 260.

Thermally controlled tripping at:

95°C +/- 5°C.

Closing time: 60 s.

Duration of seal (HTR):

minimum 60 minutes at 650°C.

Leakage: 30 l/h (at a test air pressure of 4 bar).

Ambient temperature: -20 to +60°C.

Thermal equipment trip TAS

In acc. with DIN 3586.

Inlet connection:

Rp internal thread to ISO 7-1,

PN 16 flanged connection to ISO 7005.

Outlet connection:

Rp internal thread and R external thread to ISO 7-1,

PN 16 flanged connection to ISO 7005.

Housing: steel, galvanized.

TAS..M

For fuel gases in accordance with DVGW Code of Practice G 262.

Housing: steel, chemically nickel-plated.

Closing taper and closing spring: corrosion-resistant steel.

Threaded manual valve with thermal equipment trip

AKT..R..TAS

MOP 5 (maximum operating pressure) to EN 331.

Type	Max. inlet pressure $p_{U \max.}$ [bar]	Max. operating pressure GT* with thermal capacity up to 650°C [bar]
AKT 25R10TAS	5	GT1
AKT 50R50TAS	5	GT5

* Gas temperature resistance = GT

Rp internal thread to ISO 7-1.

AKT..R10TAS

Housing: brass, nickel-plated

Ball: brass, chromium-plated

Seal: PTFE (Teflon)

Spindle seal: Viton

AKT..R50TAS

Manual valve housing: brass, chromium-plated

TAS housing: steel, galvanized

Ball: brass, chromium-plated

Seal: PTFE (Teflon)

Spindle seal: Viton

Flanged manual valve with thermal equipment trip

AKT..F..TAS

PN 16 flanged connection to ISO 7005

Type	Max. inlet pressure $p_{U \max.}$ [bar]	Max. operating pressure GT* with thermal capacity up to 650°C [bar]
AKT..50TAS	5	GT5

* Gas temperature resistance = GT

When using high temperature resistant screws (up to 650°C pursuant to DIN 267, Part 13), the max. inlet pressure $p_{U \max.}$ and the max. operating pressure GT increase to 16 bar.

Technical data

Housing: GGG 40

Ball: Ms58, chromium-plated

Seal: PTFE (Teflon)

Spindle seal: Viton

Overall length L pursuant to EN 558-1, line 1.

8.1 Dimensions

8.1.1 TAS

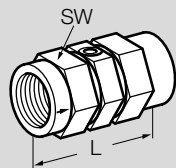

TAS 15-25..M

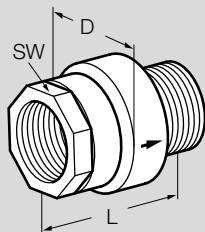

TAS 32-50IA,
TAS 32-50II

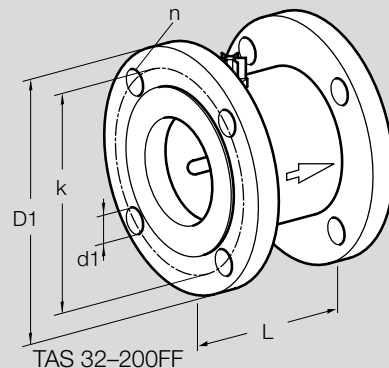

TAS 32-200FF

Type	Connection		Dimensions							Weight
	Input	Output	L mm	SW	D mm	D1 mm	k mm	d1 mm	n	kg
TAS 15IA50M	Rp 1/2	R 1/2	46	27	-	-	-	-	-	0.1
TAS 15II50M	Rp 1/2	Rp 1/2	55	27	-	-	-	-	-	0.2
TAS 20IA50M	Rp 3/4	R 3/4	49	32	-	-	-	-	-	0.2
TAS 20II50M	Rp 3/4	Rp 3/4	61	32	-	-	-	-	-	0.2
TAS 25IA50M	Rp 1	R 1	56	41	-	-	-	-	-	0.3
TAS 25II50M	Rp 1	Rp 1	69	41	-	-	-	-	-	0.4
TAS 32IA50	Rp 1 1/4	R 1 1/4	90	50	63	-	-	-	-	0.7
TAS 32II50	Rp 1 1/4	Rp 1 1/4	90	50	63	-	-	-	-	0.8
TAS 32FF50	32	32	90	-	-	140	100	18	4	4.2
TAS 40IA50	Rp 1 1/2	R 1 1/2	90	60	72	-	-	-	-	0.9
TAS 40II50	Rp 1 1/2	Rp 1 1/2	90	60	72	-	-	-	-	1.1
TAS 40FF50	40	40	90	-	-	150	110	18	4	4.5
TAS 50IA50	Rp 2	R 2	110	70	85	-	-	-	-	1.4

Technical data

Type	Connection		Dimensions							Weight
	Input	Output	L mm	SW	D mm	D1 mm	k mm	d1 mm	n	kg
TAS 50II50	Rp 2	Rp 2	110	70	85	–	–	–	–	1.5
TAS 50FF50	50	50	110	–	–	165	125	18	4	6.6
TAS 65FF50	65	65	125	–	–	185	145	18	4	8.8
TAS 80FF50	80	80	125	–	–	200	160	18	8	10.3
TAS 100FF50	100	100	175	–	–	220	180	18	8	13.7
TAS 125FF50	125	125	175	–	–	250	210	18	8	20.8
TAS 150FF50	150	150	200	–	–	285	240	22	8	26.3
TAS 200FF50	200	200	200	–	–	340	295	22	12	37.5

8.1.2 AKT..TAS

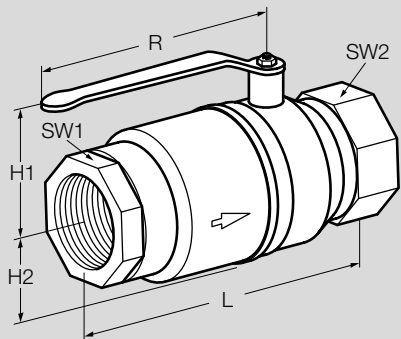

AKT 15-25R10TAS, AKT 32-50R50TAS

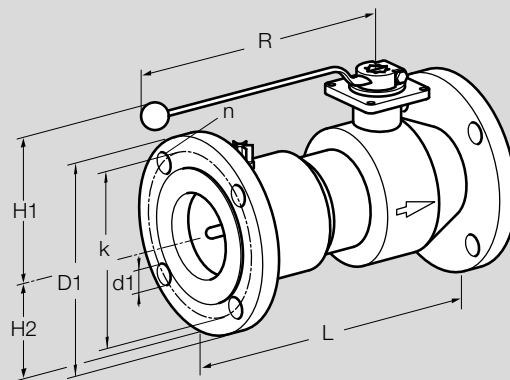

AKT 25-150F50TAS

Type	Connection	Dimensions										Weight
		L	SW1	SW2	H1	H2	R	D1	k	d1	n	
		mm	mm	mm	mm	mm	mm	mm	mm	mm	mm	kg
AKT 15R10TAS	Rp ½	84	25	25	42	16	100	-	-	-	-	0.3
AKT 20R10TAS	Rp ¾	96	31	31	45	20	100	-	-	-	-	0.4
AKT 25R10TAS	Rp 1	109	41	41	54	23	120	-	-	-	-	0.7
AKT 25F50TAS	25	160	-	-	114	58	165	115	85	14	4	4.0
AKT 32R50TAS	Rp 1¼	146	48	50	58	30	121	-	-	-	-	1.3
AKT 32F50TAS	32	180	-	-	125	70	165	140	100	18	4	5.9
AKT 40R50TAS	Rp 1½	151.5	54	55	73	36	159	-	-	-	-	1.8
AKT 40F50TAS	40	200	-	-	136	75	185	150	110	18	4	7.0
AKT 50R50TAS	Rp 2	185.5	66	70	81	43	159	-	-	-	-	2.9
AKT 50F50TAS	50	230	-	-	143	83	185	165	125	18	4	8.8
AKT 65F50TAS	65	290	-	-	158	93	230	185	145	18	4	15.8
AKT 80F50TAS	80	310	-	-	186	100	360	200	160	18	8	19.0
AKT 100F50TAS	100	350	-	-	203	110	360	220	180	18	8	27.5
AKT 125F50TAS	125	400	-	-	223	225	360	250	210	18	8	50.5
AKT 150F50TAS	150	480	-	-	230	143	625	285	240	22	8	71.0

9 Maintenance cycles

TAS and AKT..TAS require little servicing. After tripping, the valves have to be replaced.

Fore more information

The Honeywell Thermal Solutions family of products includes Honeywell Combustion Safety, Eclipse, Exothermics, Hauck, Kromschroder and Maxon. To learn more about our products, visit ThermalSolutions.honeywell.com or contact your Honeywell Sales Engineer.

Elster GmbH
Strothweg 1, D-49504 Lotte
T +49 541 1214-0
hts.lotte@honeywell.com
www.kromschroeder.com

Global centralized service deployment coordination:
T +49 541 1214-365 or -555
hts.service.germany@honeywell.com

© 2019 Elster GmbH

We reserve the right to make technical modifications in the interests of progress.

Honeywell

**krom
schroder**